

VIC./TAS.

# Rainwater solutions

There's a LYSAGHT rainwater solution to suit every Australian home.

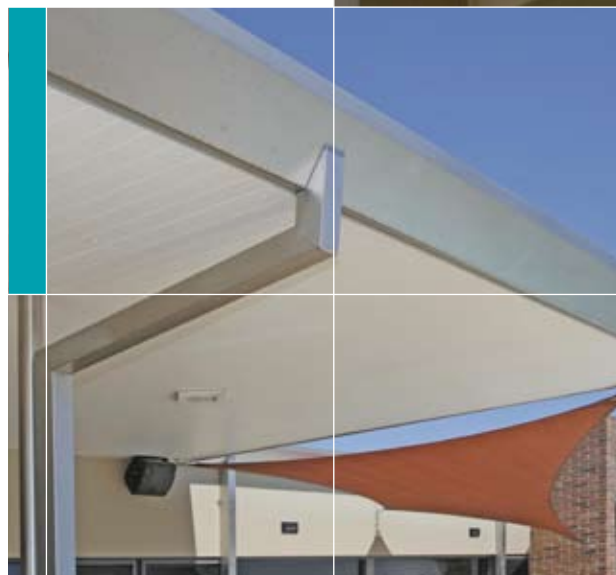

- LYSAGHT® QUAD gutter
- LYSAGHT® OGEE gutter
- LYSAGHT® HALF ROUND gutter
- LYSAGHT TRIMLINE® gutter
- LYSAGHT SHEERLINE® gutter
- LYSAGHT NOVALINE® fascia
- LYSAGHT® Downpipes & accessories
- LYSAGHT® Rainheads & tradework



**LYSAGHT**

# Water overflow in domestic rainwater systems

Under the Environmental Planning and Assessment Act 1979 and its Regulations, all building work must be carried out in accordance with the Building Code of Australia (BCA). In addition to referring to Australian Standards AS/NZS 3500.3 (2003), and AS/NZS 3500.5 (2000), the BCA also contains requirements for the disposal of surface water in Volume One, in Performance Requirements FP1.2 and FP 1.3, and in Volume Two, in Part 3.5.2, namely, Performance Requirement P2.2.1 and Clauses 3.5.2.1 and 3.5.2.4.

The most common means to satisfy these requirements for roof drainage (ie. guttering) installations is via compliance with the National Plumbing and Drainage Code AS/NZS 3500.3 - 2003.

Furthermore, in each state and territory it is necessary to satisfy the relevant regulation. For example, the NSW Code of Practice for Plumbing and Drainage (2006) adopts AS/NZS 3500.3-2003 and associated amendments. (Further information is available at [www.deus.nsw.gov.au/water/plumbing.asp](http://www.deus.nsw.gov.au/water/plumbing.asp))

In the design and detailing of a roof drainage system consideration must be given to a range of the factors such as rainfall intensity, roof catchment area, gutter size/capacity, gutter fall, gutter outlets (sumps, rain-heads, nozzles), downpipe size, quantity and placement, overflow consideration, material selection, jointing, etc.

For residential roof drainage systems high fronted gutters are a popular aesthetic choice to hide the lower edge of tiles or roof cladding. Some simple overflow methods that can be employed on high fronted gutters are listed below;

- A) Methods related to the design and installation of roof drainage systems ;
- Slotted front of gutter - a simple and popular choice which allows for water overflow through the slots visible on the front face of the gutter.
  - Specifically located overflows as permitted in the BCA ie;
  - Inverted downpipe drop/pop at high points in the gutter but set at a level below the fascia top.
  - Stop ends cut down to a lower level to act as a weir. Stop ends weirs could be hidden at the high point of the gutter and designed as part of an expansion joint.
  - Rain-heads with overflow weir.
  - Holes, slot, or weir at downpipes.
  - Gap between the fascia and the gutter back – a packer is inserted between the gutter back and the fascia.

or any of a number of other proprietary systems and trade solutions.

- B) Methods related to alternative building design methods;
- Unlined eaves - eliminates the issue where the house design suits.
  - Gutter installed such that the gutter front is fully below the top of the fascia.
  - Design for a higher rainfall intensity, as used for internal box gutters.
  - Back flashing - where gutter support brackets allow back flashing installation (eg external brackets).

The detailing and sizing of the selected overflow method/s is normally completed by the designer/installer, but must be adequate for the situation and must meet the relevant performance requirement of the BCA and Australian Standards.

While there may be some variations from state to state, contractors who install guttering systems are generally required to hold an appropriate licence. In NSW, for example, a licence in the category of Builder, Plumber or Roof Plumber issued by the Office of Fair Trading is required and it is an offence to undertake this work without an appropriate licence. The work is required to comply with the appropriate codes and standards.



Statutory warranties normally apply and consumers have a right to lodge a complaint and have it dealt with by the appropriate authority. In NSW, for example, the statutory warranty is 7 years under the Home Building Act.

In the installation of the roof drainage system, particular focus should be given to the following;

- Attention to the use of compatible materials for drainage system components, leaf-guard type system components and compatible fasteners/sealants to connect and seal the components.
- The position of the gutter in relation to the fascia.
- Installation of the specified gutter and downpipes, ensuring that downpipes are installed in the correct locations and numbers.
- Gutter fall, ensuring sufficient fall and that it is in the direction of the downpipes.
- Overflow has been considered and specific details are installed where required (such as when the gutter front is higher than the top of the fascia).

During the installation all debris and loose waste materials (swarf, fasteners, etc) must be cleaned off at the end of each day and at the completion of the installation to prevent blockages of the drainage system or deterioration of the individual components. Any protective films should also be removed as part of the installation process.

In the longer term, the ability of a roof drainage system to handle overflow will also depend on the regular cleaning of the system. For example the removal of plant or animal matter (leaves, fungal growth, dropping, nests, etc.) and debris from gutters, leaf-guard type systems and the gutter overflow devices to ensure free drainage of water.

To ensure a long life the roof drainage system the maintenance requirements of the roof drainage system should be forwarded to the occupier/owner of the building and should be fulfilled. Adequate maintenance is a requirement of rainwater good warranties.

The following illustrations show continuous and non-continuous overflow measures that may be used in combination with each other to meet the necessary requirements.

Please note that non-continuous measures may become blocked anywhere along their length, so non-continuous overflow measures may not be sufficient to prevent water from flowing back into a building.

### Continuous overflow measures

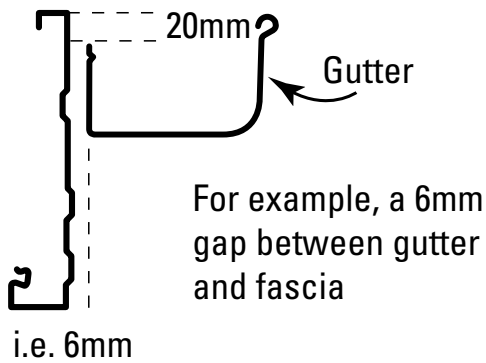
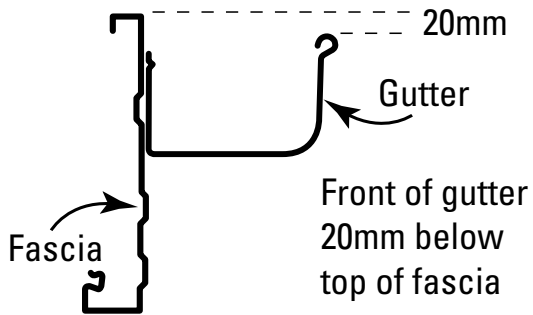

### Non-continuous overflow measures

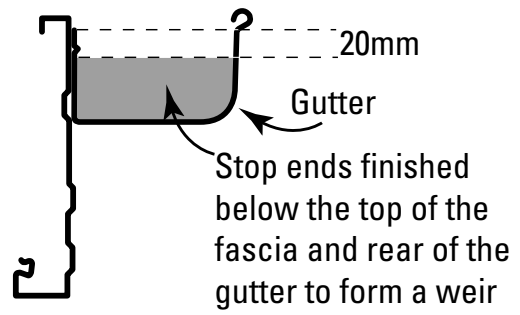
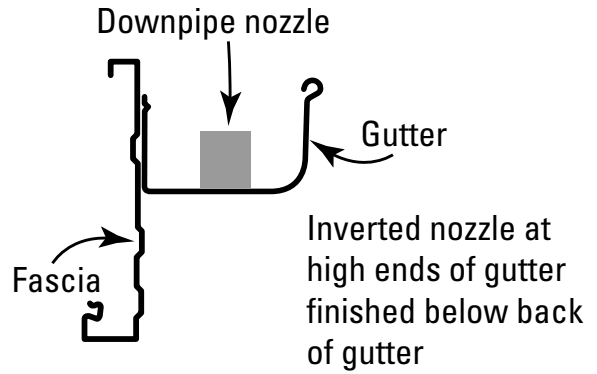

Other non-continuous measures include the use of rainwater heads with slots as weirs.

Slotted gutters may also provide an overflow measure, however slots must be of sufficient size.



Typical overflow from slotted gutter (gutter shown is not available in all areas.)

# Guidance on designing a perimeter drainage system for a domestic roof

Roof drainage systems can be affected by a number of variables and must be designed and detailed by a suitable qualified trade or professional. The design of roof drainage aims to protect people, property and the building. The designed drainage system must be installed under the supervision of a qualified trade or professional. The steps of the design process are illustrated below.

1. Determine average recurrence interval (ARI)
2. Obtain rainfall intensity of site
3. Work out roof dimensions.
4. Catchment area with slope
5. Work out area for proposed eaves gutter.
6. Determine catchment area per downpipe
7. Determine number of downpipes required
8. Determine location of downpipes and high points
9. Check catchment area for each downpipe.
10. Determine downpipe size
11. Overflow measures

## Design Procedure

1. Decide on the average recurrence interval (ARI). Where significant inconvenience or injury to people, or damage to property (including contents of a building), is unlikely, a minimum ARI can be 20 years. If these conditions are likely, 100 years is recommended.
2. Determine rainfall intensity for the site from Table 1. More data is in AS/NZS 3500.3.2:2003.
3. Sketch a roof plan showing dimensions in plan view, pitch of roof, layout of ridges and valleys and large roof penetrations.
4. Calculate the catchment area of the roof from the plan. To allow for the slope of the roof, increase the plan area by 1% for every degree of pitch up to 36°. For pitches over 36° refer to AS 3500.3: 2003.
5. Get the effective cross-sectional area of the gutter you intend to use from Table 2.
6. Using the cross-sectional area of the gutter on the graph in Figure 1, determine the catchment area per downpipe.
7. Calculate (as a first test) the minimum number of downpipes required for the selected gutter using the equation:

$$\text{Number of downpipes (min.)} \left\} = \frac{\text{Total catchment area of the roof}}{\text{Catchment area (determined in 6)}}$$

Round the number of downpipes up to the next whole number.

8. On the plan, select locations for the downpipes and the high points in the gutters. Where practical, the catchments for each downpipe should be about equal in area.  
  
When selecting the location of high points and downpipes, consideration should also be given to proximity to high concentrations of water flow (e.g. valley gutters, diversions around large roof penetrations, dormers, etc.) More guidance is given in AS/NZS 3500.3:2003 and BCA.

Calculate the area of each catchment for each downpipe.

9. With the area of your eaves gutter, check that the catchment area for each downpipe, calculated in Step 8, is equal to or less than the catchment area shown by the graph.

If a catchment area is too big then you can:

- Increase the number and size of downpipes;
- Reposition the downpipes and/or the high points;
- Choose a gutter with bigger effective cross-sectional area, then repeat the above from Step 6.

11. Decide on the downpipe size. Recommendations in AS/NZS 3500.3:2003 on downpipe sizes. As an approximate guide, the area of round pipes should be equal to the area of the gutter, whilst the area of square or rectangular pipes may be 20% smaller (Table 2).
12. Consider measures to counter overflow of gutters into the building. Consideration of overflow at high concentrations of water flow may need to be given.

Install gutters with a suitable fall to avoid ponding and to allow water to easily flow away. Steeper falls are preferred for prolonged life of the gutter. More information can be found in our publication, 'Water Overflow & Residential Gutters'. Refer to the BCA and the Australian Standards for more guidance.

	For overflow of eaves gutters once in 20 years mm/hour	For overflow of gutters once in 100 years mm/hour
<b>VIC.</b>		
Bacchus Marsh	126	189
Ballarat	127	184
Benalla	133	187
Geelong	118	172
Hamilton	120	184
Healesville	129	182
Horsham	120	174
Korumburra	116	168
Lakes Entrance	124	179
Melbourne	127	186
Mildura	125	174
Morwell	129	196
Orbost	130	188
Stawell	127	185
Wonthaggi	114	165
<b>TAS.</b>		
Bridgewater	101	156
Burnie	118	191
Deloraine	108	165
Dover	97	161
Flinders Island	128	184
Hobart	99	155
Kingston	98	154
Launceston	101	150
Mt Wellington	122	191
New Norfolk	100	166

**Table 1 Average recurrence interval (ARI)**

Design rainfall intensities adapted from AS 2180:1986

The steps in the design process are for a perimeter drainage system using the standard roll-formed rainwater products (gutters) installed at the building eaves. Drainage systems for larger roofs use box gutters at the perimeter and internally. Box gutter systems are thoroughly treated in AS/NZS 3500.3:2003 and HB114:1998.

It is assumed that the eaves and gutters will have a gradient of 1:500 or steeper.

**Figure 1**

Cross-sectional area of eaves gutters required for various roof catchment areas (where gradient of gutter 1:500 and steeper). (Adapted from AS 3500.3: 2003)

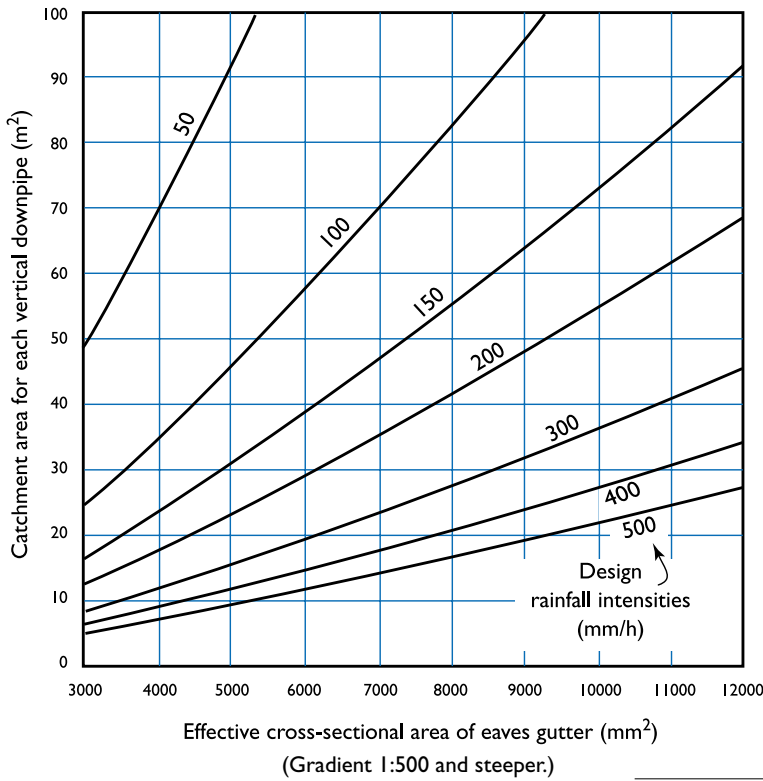

**Table 2**  
Gutter areas and downpipes

	Slotted yes/no	Effective cross-section mm <sup>2</sup>	Minimum standard downpipe sizes to suit gutters (Gutter fall ≥ 1:500)	
			Round (diameter) mm	Rectangular or square mm
QUAD Hi-front	yes	5225	90	100 x 50
QUAD Hi-front	no	5809	90	100 x 50
OGEE	no	5242	-	100 x 50
HALF ROUND 150	no	9200	non standard	100 x 75*
TRIMLINE	yes	6244	90	100 x 50
TRIMLINE	no	7800	100	100 x 75
SHEERLINE	yes	7600	100	100 x 75
SHEERLINE	no	8370	non standard	100 x 75

Values calculated in accordance with AS/NZS 2179.1:1994

Non standard downpipe and nozzle/pop is required

\*Non standard nozzle/pop is required to suit rectangular downpipe.

**Example**

Find the minimum catchment area for each downpipe on a house in Orbost using Quad Hi-front gutter.

**METHOD**

Using the gutter cross sectional area taken from Table 2 (shown across the bottom of the graph) draw a line upwards until it intersects with the Design rainfall intensity (Table 1). Draw a line at 90° to determine the catchment area for each downpipe.

**DATA**

Design rainfall intensity = 130 (Table 1)

Gutter area = 5804 (Table 2)

**SOLUTION** (from Figure 1)

Catchment area for each downpipe = 44 m<sup>2</sup>

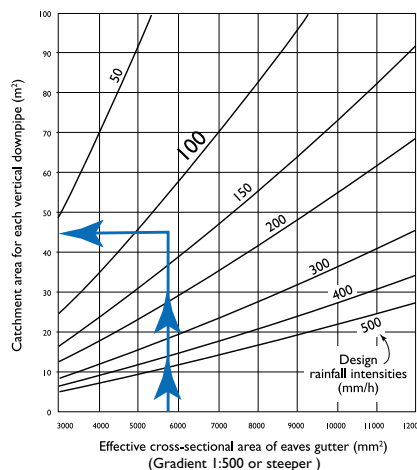

# Rainwater products

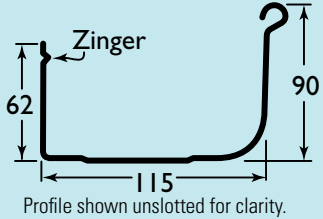
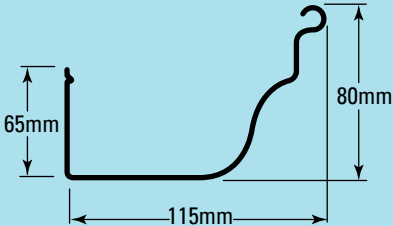
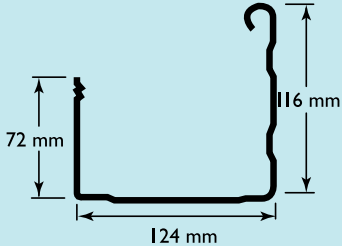
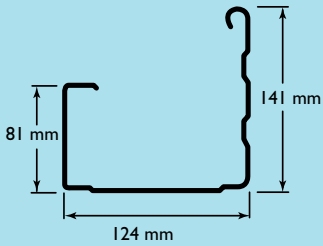
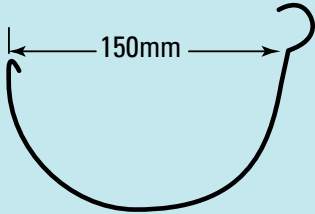
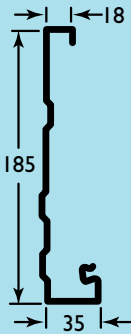
<p><b>QUAD</b></p>	 <p>Profile shown unslotted for clarity.</p>	<ul style="list-style-type: none"> <li>• Classic design that is the leading choice in new homes</li> <li>• The high front profile design obscures the roofline for a more attractive finish</li> <li>• Compatible with NOVALINE Fascia System for quick, easy attachment to the building</li> <li>• Available with optional slotting to allow overflow where alternative overflow devices are not installed</li> <li>• Suitable for steel or tile roofs</li> </ul>
<p><b>OGEE</b></p>	 <p>Profile shown unslotted for clarity.</p>	<ul style="list-style-type: none"> <li>• Truly distinctive look compatible with both traditional and modern buildings</li> <li>• Popular style so a complete range of accessories is available</li> <li>• Compatible with NOVALINE Fascia System for quick, easy attachment to the building</li> <li>• Suitable for steel or tile roofs</li> </ul>
<p><b>TRIMLINE</b></p>	 <p>Profile shown unslotted for clarity.</p>	<ul style="list-style-type: none"> <li>• Slim, elegant square gutter particularly suited to domestic applications that is fast and simple to install</li> <li>• Concealed fixing offers clean, attractive 'trim' lines</li> <li>• Compatible with NOVALINE Fascia System for quick, easy attachment to the building</li> <li>• Available with optional slotting to allow overflow where alternative overflow devices are not installed</li> <li>• Suitable for steel or tile roofs</li> </ul>
<p><b>SHEERLINE</b></p>	 <p>Profile shown unslotted for clarity.</p>	<ul style="list-style-type: none"> <li>• Popular for home improvement projects like patios, pergolas and sheds and for use with high profile roofing laid at low pitches or traditional domestic roofs requiring large water carrying capacity</li> <li>• Concealed fixing offers clean and seamless finish</li> <li>• SHEERLINE capping available for trimming roof edges</li> <li>• Available with optional slotting to allow overflow where alternative overflow devices are not installed</li> </ul>
<p><b>Half round</b></p>	 <p>Profile shown unslotted for clarity.</p>	<ul style="list-style-type: none"> <li>• Large water carrying capacity for high rainfall areas and large roof sizes</li> <li>• Unique curved base allows self-cleaning and prevents build-up of water and dirt</li> <li>• Complemented with a complete range of accessories</li> </ul>
<p><b>NOVALINE fascia</b></p>	 <p>Profile shown unslotted for clarity.</p>	<ul style="list-style-type: none"> <li>• State-of-the-art fascia system</li> <li>• Integrates perfectly with QUAD, OGEE and TRIMLINE® gutters</li> <li>• Replaced traditional timber fascia which reduces painting and maintenance</li> <li>• Makes fixing gutters quick and easy using spring clips</li> <li>• Extensive range of accessories available</li> </ul>

LYSAGHT quality gutters are available in unpainted ZINCALUME® steel and in a range of COLORBOND® steel pre-painted colours to match or contrast your roof.

## Accessories

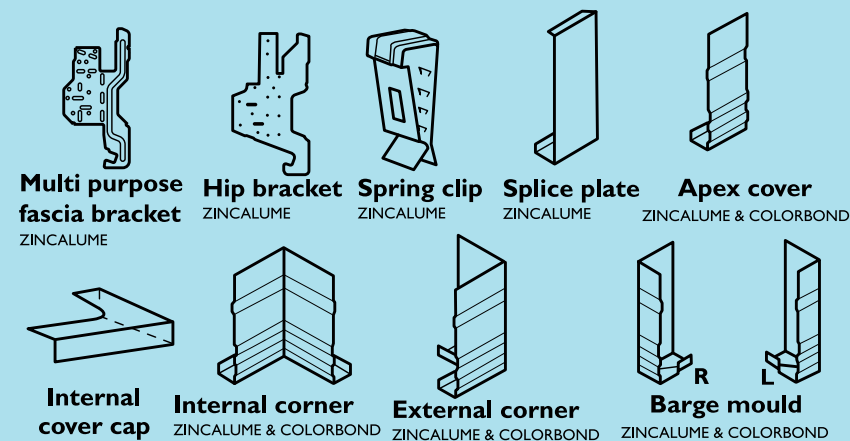
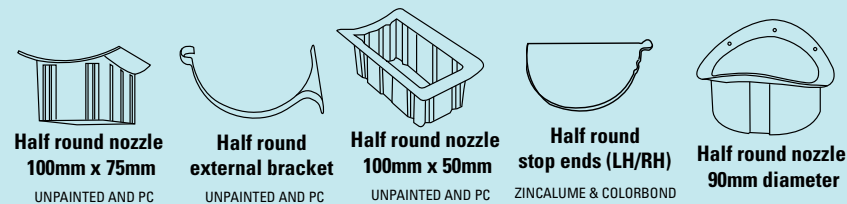
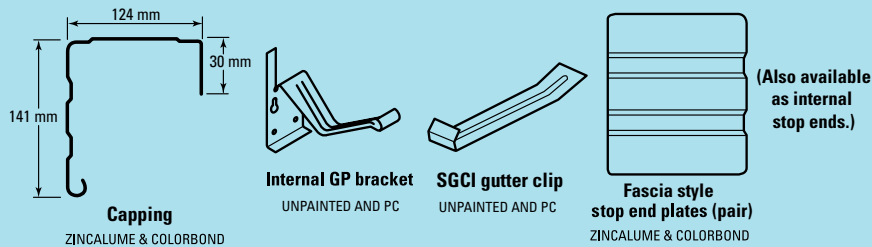
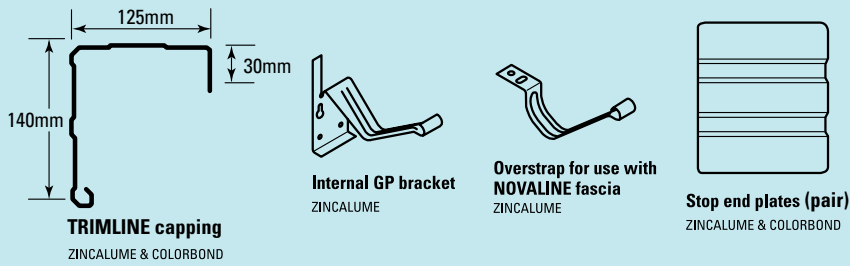
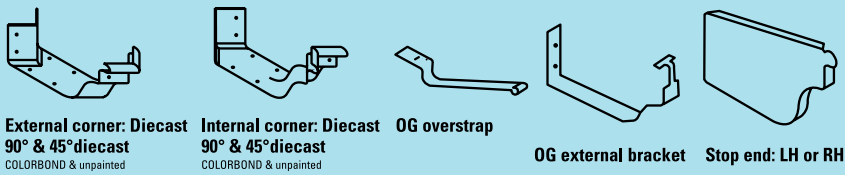
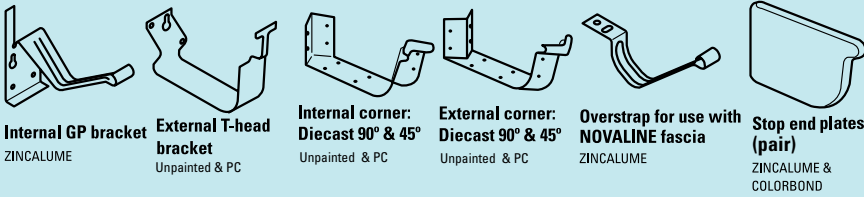

# Downpipes & accessories

Completing your rainwater system



Finish your roof with the distinctive style of the LYSAGHT downpipes and accessories.

These downpipes and accessories are compatible with the NOVALINE® fascia system, and with a wide range of gutters.

All LYSAGHT downpipes and accessories are made from galvanised or ZINCALUME® steel, which means they are strong and made to last.

Most downpipes and accessories are available in unpainted ZINCALUME® steel and a range of COLORBOND® steel colours to match or contrast with your roof. They are compatible with steel and tile roofs.

A wide range of rectangular, square and round downpipes available to complement all building styles. Some dimensions and availability may vary slightly from region to region.

## Downpipes

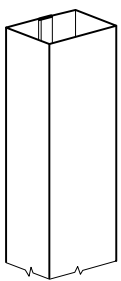

Rectangular or square

100 x 50  
100 x 75  
100 x 100

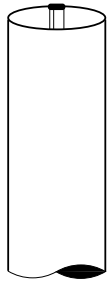

Round

75  
90  
100

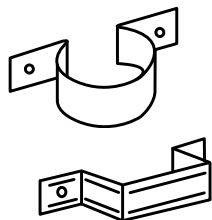

Astragals/brackets

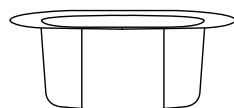

Uni-drop

## Accessories

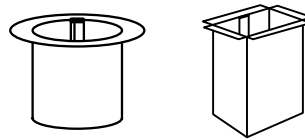

Pops/Nozzles

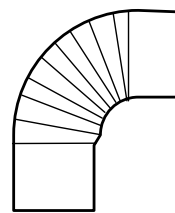

Downpipe bends  
(rectangular and circular)

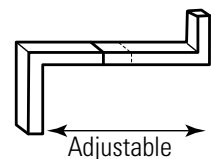
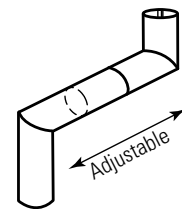

Downpipe offsets  
(rectangular and circular)



# Rainheads & tradework

Made to order  
to your specifications

## LYSAGHT standard rainwater heads

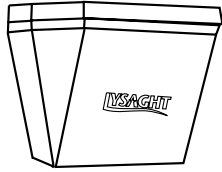

**Dimensions**  
390 W x 300 H x 250 D

**Materials**  
COLORBOND® steel  
ZINCALUME® steel

## Tapered rainwater heads (downpipe outlet not included)

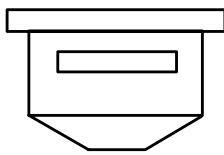

**Dimensions**  
Standard blank  
Small: 380 x 175 x 200 mm  
Large: 450 x 250 x 250 mm  
Or to your dimensioned drawing.

**Materials**  
COLORBOND® steel  
ZINCALUME® steel

## Custom made square rainwater heads (downpipe outlet not included)

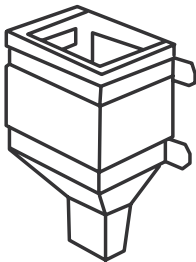

**Dimensions**  
To your dimensioned drawing.

**Materials**  
COLORBOND® steel  
ZINCALUME® steel

## Custom made round rainwater heads

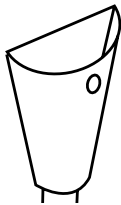

**Dimensions**  
To your dimensioned drawing.

**Materials**  
COLORBOND® steel  
ZINCALUME® steel

## Corner Ogee rainwater head

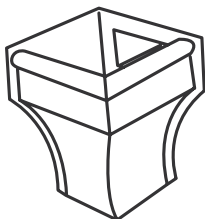

**Dimensions**  
To your dimensioned drawing.

**Materials**  
Galvanised steel  
Copper

## Ogee rainwater head

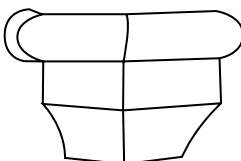

**Dimensions**  
Small: 310 x 200 mm  
Large: 400 x 250 mm  
Or to your dimensioned drawing.

**Materials**  
Galvanised steel  
Copper

- LYSAGHT rainwater heads, flashing, tradework and box gutters, are also available made to order. Provide us with a picture, drawing or template and we can manufacture for you.
- To order non-standard rainwater heads, supply detailed drawings showing front and side elevations with dimensions and nozzle size.
- Refer to the Victoria product offer for the full range of tradework and flashing products available. Ask your technical sales representative for details.

# Installation advice

Get it right first time  
with LYSAGHT products

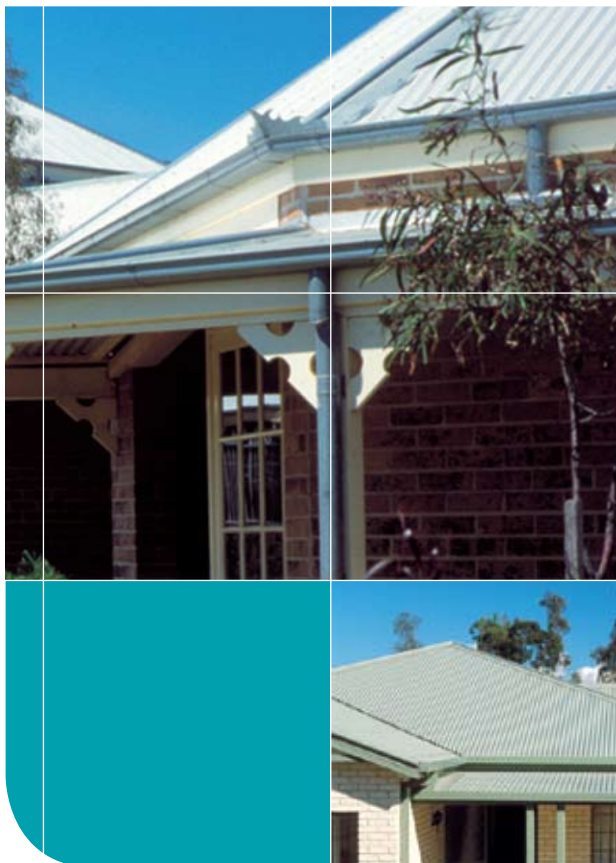

## Bracket spacing

When the gutters are attached to NOVALINE fascia, then the gutter bracket spacing should mirror the spacing of the NOVALINE brackets (ie 600mm & 1200mm), and the gutter brackets should be adjacent to the NOVALINE brackets.

However, when the gutters are fixed to other fascias then the weight of the water carried by the gutter should determine spacing required - however spacing should not exceed 1200mm maximum.

## Fall

Install gutters with a suitable fall to avoid ponding and to allow water to easily flow away. Steeper falls are preferred for prolonged life of the gutter. Refer to the BCA and the Australian Standards for guidance.

## Metal & timber compatibility

Lead, copper, bare steel and green or some chemically-treated timber are not compatible with this product; thus don't allow any contact of the product with those materials, nor discharge of rainwater from them onto the product. If there are doubts about the compatibility of other products being used, ask for advice from our information line.

## Roof drainage system design

Roof drainage systems should be designed and detailed by a suitably qualified trade or professional in accordance with the BCA and the Australian Standards. Particular reference should be made to the correct sizing of gutter; quantity and placement of downpipes; and the provision of appropriate overflow devices. (Page 2-3).

## Adverse conditions

If these products are to be used within 1km of marine, severe industrial, or unusually corrosive environments, ask for advice from our information line.

## Installation Advice

The roof drainage system should be installed using good trade practices and by a certified installer.

For sealed joints use screws or rivets and neutral-cure silicone sealant branded as suitable for use with galvanised or COLORBOND/ZINCALUME® steel.

## Clean up

Remove all plastic cover strips from product and dispose of correctly.

Sweep all metallic swarf and other debris from roof areas, gutters, downpipes, overflow devices and all other roof drainage components, at the end of each day and at the completion of the installation.

## Gutter Maintenance

The roof drainage system (gutter, downpipes, overflow devices and all other components) must be cleaned out on a regular basis.

# Gutter maintenance



1) A typical suburban gutter clogged with leaf litter prior to cleaning.



2) Wear correct protection when clearing leaves and twigs.



3) When litter is removed, the layer of hardened dirt is revealed below.



## Cleaning Gutters

Twigs, dust, leaves and fungal matter (debris) should be removed regularly from gutters - as failure to do so voids your warranty.

\* Sweep debris into a pile using a stiff, soft bristled brush (shovels or hard tools should not be used).

\* The whole roof and gutter should then be washed down with a hose, including high ends of gutters (possibly protected by overhangs), rain heads, water spouts and overflow locations.

A well maintained gutter/downpipe will make your rainwater system provide years and years of trouble-free service.



4) Rinse the gutter with water to soften and break up the dirt.

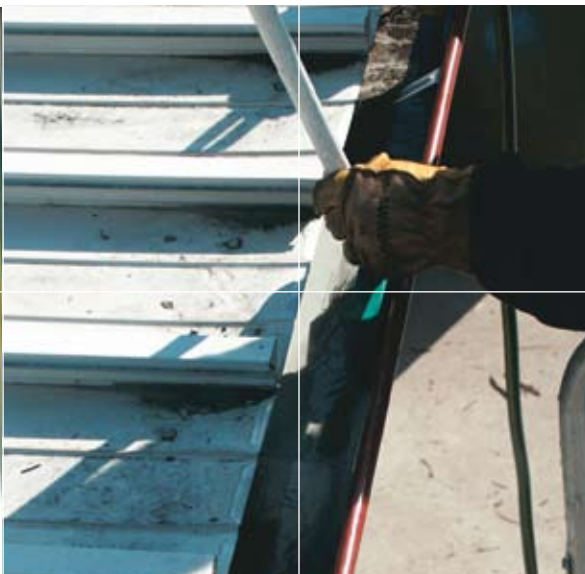

5) Use a soft bristle brush and sweep the dirt out. Rinse again.



6) When the gutter has been cleaned, it should look like this.



When you specify LYSAGHT products you have the added advantage of dealing with a company whose expertise and experience with steel stretches back for 150 years.

BlueScope Lysaght offers a full range of accessories to complete almost any rainwater system. Refer to the Victoria product offer for full range.

### **Disclaimer, warranties and limitation of liability**

This publication is intended to be an aid for all trades and professionals involved with specifying and installing LYSAGHT products and not to be a substitute for professional judgement.

Terms and conditions of sale available at local BlueScope Lysaght sales offices.

Except to the extent to which liability may not lawfully be excluded or limited, BlueScope Steel Limited will not be under or incur any liability to you for any direct or indirect loss or damage (including, without limitation, consequential loss or damage such as loss of profit or anticipated profit, loss of use, damage to goodwill and loss due to delay) however caused (including, without limitation, breach of contract, negligence and/or breach of statute), which you may suffer or incur in connection with this publication.

© Copyright BlueScope Steel Limited October 21, 2009

Please check the latest information which is always available at:

**[www.lysaght.com](http://www.lysaght.com)**

Technical enquires: [steeldirect@bluescopesteel.com](mailto:steeldirect@bluescopesteel.com) or call 1800 641417

LYSAGHT®, COLORBOND®, ZINCALUME®, NOVALINE®, SHEERLINE®, TRIMLINE® and BlueScope are registered trade marks of BlueScope Steel Limited, ABN 16 000 011 058.

